



Qinhuangdao Xinchi Photoelectricity Technology Co.,Ltd

DOC NO: XCJY/04-PS002

REV: A/0

Effective Date: 10/07/2011

PAGE: 1 of 7

Whatsapp



Lithium-ion Battery

PRODUCT SPECIFICATION

MODEL : XC-CPM-HEV

NOMINAL CAPACITY : 8.0Ah

Contact person: Carl

Sales manager

Technology supervisor

Email: xinchibatterysales@gmail.com

Phone/Whatsapp: +86 130 1196 2820

www.sinclithiumbattery.com

Liaoning Xinchi Lithium Technology Co.,Ltd

Address: No.10, North 2nd Road, Dalinghe Industrial Park, Linghai City, Jinzhou, Liaoning, China

QINHUANGDAO XINCHI PHOTOELECTRICITY TECHNOLOGY CO., LTD.

Address: At The 275-KM Spot To No.102 National Road South, Funing County, Qinhuangdao City, Hebei, China



1. SCOPE

This Product Specification describes the features and requirements of the XC-CPM-HEV plastic-aluminum-packaged lithium-ion battery to be supplied to the customers by Qinhuangdao Xinch Photoelectricity Technology Co., Ltd.

2. DESCRIPTION AND MODEL

2.1. Description: Plastic-Aluminum-Packaged Lithium-ion Battery

2.2. Model: XC-CPM-HEV (8.0Ah)

3. APPEARANCE

No deformation or flaw, smooth surface, dry, non- scrape and non-dirt, and clear signs.

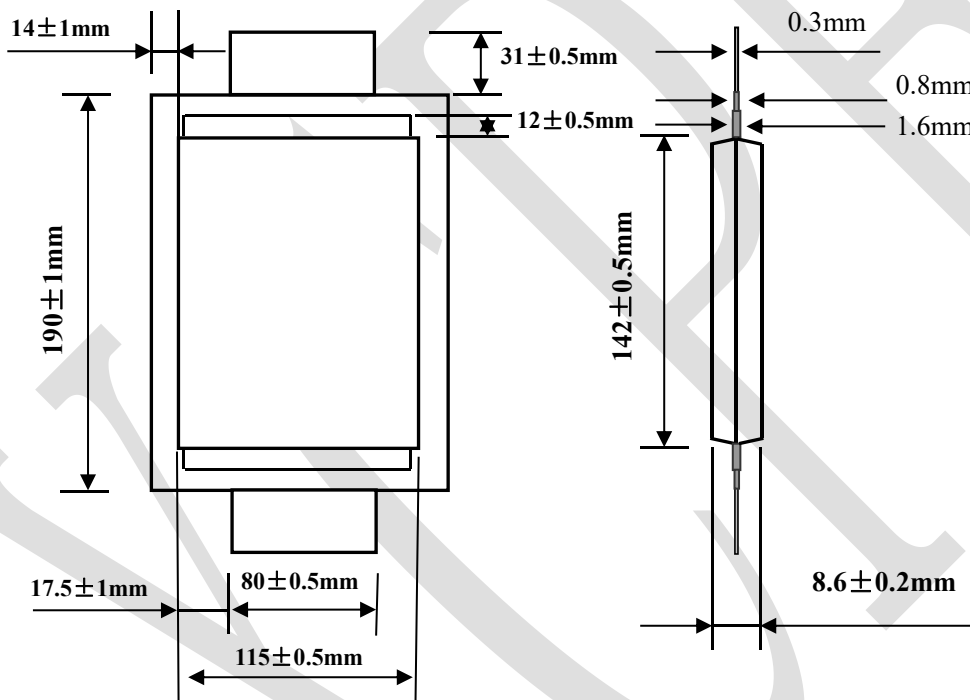



4. GENERAL SPECIFICATIONS

Items	Parameters
Nominal Voltage	3.6V
Nominal Capacity	8.0Ah (1C ₁ A charge/discharge)
Internal Resistance	≤1.3m Ω
Cut-off Charge Voltage	4.20V±0.01V
Standard Charge Method	Charge the battery at a constant current of 8.0A (1C ₁ A) to 4.2V, and then charge at a constant voltage of 4.2V(CV) until the charge current is ≤0.85A
Max. Charge Current	Continuous charge: 40A (5C ₁ A)
	Momentary charge:80A (10C ₁ A) (≤30s)
Standard Discharge Method	Current: 8.0A (1C ₁ A)
	Cut-off discharge voltage: 2.75V
Max. Discharge Current	Continuous discharge: 160A (20C ₁ A)
	Momentary discharge: 192A (24C ₁ A) (≤30s)
Cycle-Life (at room temperature)	≥2000 cycles (100%DOD charge at 1C ₁ A and discharge at 1C ₁ A, Remaining Capacity≥70% Nominal Capacity)
Working Temperature	Charge : 0°C ~ 40 °C
	Discharge: -20°C ~ 55°C
Storage Condition	-10°C ~ 40 °C (0 ~ 30 °C recommended) Humidity 30±20%
Weight	305±5g
Retention Capacity	>95%(after 28days' storage at 25°C)
Casing Material	Plastic aluminum
Tab Materials	Cathode tab: Aluminum Anode tab: copper (nickel surfaced)
Performance Curve	Details as per attached list(page 8)

5. STANDARD TEST CONDITIONS

(Reference to QC/T734-2006 Lithium-ion Battery Standard for Electric Vehicles)

5.1. Measuring Equipment

5.1.1 Voltmeter: internal resistance>1000Ω/v, accuracy≥0.5;

5.1.2 Ampere-meter: accuracy≥0.5;

5.1.3 Temperature meter: nominal accuracy≥0.5°C, scale division<1°C;

5.1.4 Calculagraph: accuracy on hours, minutes, and seconds, accuracy≥±0.1%;

5.1.5 Dimension measure: scale division<1mm;

5.1.6 Weight measure: accuracy ≥±0.05%.

5.2. Unless otherwise specified, all tests shall be performed at 15°C ~ 35°C, humidity of 25 % ~ 85 % , and atmospheric pressure of 86kPa~106kPa.

5.3. All tests shall be performed per6.1. Unless specifically defined, the battery for test shall be newly delivered, or at least has only been delivered for a month.

5.4. Definition:



“C₁”—nominal capacity of a fully charged battery which is discharged to its end voltage in one hours (Ah)
“C₁A” —discharge current value with absolute value of C₁.

6. BATTERY PERFORMANCE TESTS

6.1. Standard Charge Method

At $20 \pm 5^{\circ}\text{C}$, discharge the battery at 8.0A ($1C_{1A}$) constant current to 2.75V, store for 1 hour, and then charge the battery at a constant current of 8.0A($1C_{1A}$) to 4.2V. Then the battery shall be charged at constant voltage of 4.2V until the charge current is $\leq 0.80\text{A}(0.1 \times 1C_{1A})$.

6.2. Standard Discharge Method

Discharged at a constant current of 8.0A($1C_{1A}$) to 2.75V at $20 \pm 5^{\circ}\text{C}$, Then the battery shall be charged at constant voltage of 2.75V until the charge current is $\leq 0.80\text{A}(0.1 \times 1C_{1A})$.

6.3. Discharge Capacity

Store for 1 hour after being charged as per 6.1, and then discharge as per 6.2, The discharge capacity is $\geq 95\%$ of the nominal capacity.

6.4. Cycle-Life

One Cycle-Life = Charge the battery as per 6.1, and then discharge the battery as per 6.2 at $20 \pm 5^{\circ}\text{C}$, then Store for 1 hour, Check the battery capacity as per 6.3. Stop the test if the battery capacity is $< 70\%$ of the nominal capacity; The repeated times is Cycle-Life, Cycle-Life ≥ 2000 times.

6.5. Retention Capacity

Charge the battery as per 6.1, store it for 28 days at $20 \pm 5^{\circ}\text{C}$, and then discharge the battery as per 6.2 The discharge capacity is $> 95\%$ of the nominal capacity.

6.6. 20 °C Rate Discharge

Store the battery for 1 hour after being charged as per 6.1, and discharge it at a constant current of 80A ($10C_{1A}$) to 2.75V at $20 \pm 5^{\circ}\text{C}$. The discharge capacity is $\geq 90\%$ of the nominal capacity.

6.7. Safety

All the safety tests shall be done with enough protection.

6.7.1 Short-Circuit Test

Charge the battery as per 6.1, external short-circuit it for 10 min with external resistance $< 50\text{m}\Omega$. Requirement: no explosion and no fire.

6.7.2 Overcharge Test

Charge the battery as per 6.1, and charge it at 8.0A to 5V or for 90min (Stop the test when either of the two conditions occurs).

Requirement: no explosion and no fire.

6.7.3 Heating Test

Charge the battery as per 6.1, and then put it into a hot box of $85 \pm 2^{\circ}\text{C}$ for 120 min.



Requirement: no explosion and no fire.

6.7.4 Drop test

Charge the battery as per 6.1, and then drop it from 1.5m above to a 20mm hard wooden floor, one time for each side.

Requirement: no explosion, no fire, and no leakage.

6.7.5 Puncture test

Charge the battery as per 6.1, and then punch through by a steel and heat-resistant nail of ϕ 3~8mm at the speed of 10~40mm/s (the steel nail rests in the battery).

Requirement: no explosion and no fire.

6.7.6 Pressing test

Charge the battery as per 6.1, and then vertically press it by a pressing tool with a surface larger than 20cm² until the battery cracks or short-circuits internally (the voltage of the battery is 0V).

Requirement: no explosion and no fire.

7. SHIPPING

7.1. During transportation, the capacity of the battery should be <40%(voltage \leq 3.8V), and the battery should be packaged in boxes. Keep the battery from acute vibration, impact, sunlight, rain, and inversion.

7.2. During loading and unloading, the battery should be moved lightly, and do not throw, roll or press the battery.

8. STORAGE CONDITION

The battery should be stored under -10~40°C (0 ~ 30°C is recommended) in a clean, dry, and ventilated room, and keep the battery far from corrosive materials, direct sunlight, fire and heat sources.

9. WARNINGS

9.1. The recommended voltage of the battery under long-term storage is 3.6-3.7V. The battery must be charged and discharged once every three months, and at least once a month is suggested. The charge and discharge procedure is: discharging the battery at 8.5A(1C_{1A}) CC to 2.75V, then charging the battery at 8.5A(1C_{1A})CC/CV to 4.2V, then discharging the battery at 8.5A(1C_{1A}) CC to 3.6—3.7V, and then storing the battery;

9.2. Do keep the battery far from heat or fire sources;

9.3. Do not collide with pointed and flinty objects, or contact with objects that may cause short-circuit;

9.4. Do not dismantle the battery or battery pack without prior permission;

9.5. Do not short-circuit the battery by directly connecting the positive (+) and negative (-) terminals with metal sheet, or mix the battery with other objects that can easily cause short-circuit;

9.6. Do not reverse the positive (+) and negative (-) terminals or reverse charge the battery;

9.7. Do not immerse the battery in water or dampen it;

9.8. Do not mix-use the battery with dry battery or other types of batteries;

9.9. Do not throw, pierce, or strike the battery;



Qinhuangdao Xinch Photoelectricity Technology Co.,Ltd

DOC NO: **XCJY/04-PS002**

REV: **A/0**

Effective Date: **10/07/2011**

PAGE: **6 of 7**

9.10. Do charge the battery with the charger specifically designed for that purpose;

9.11. Don't directly solder the lead with the battery;

9.12. Please carefully read this Specification before using the battery.

10. RESPONSIBILITY

Please carefully read this Product Specification before using the battery, and strictly abide by this Specification. Any accident caused by non-abidance of this Specification is not the responsibility of Qinhuangdao Xinch Photoelectricity Technology Co., Ltd.

11. WRITTEN NOTICE

Qinhuangdao Xinch Photoelectricity Technology Co., Ltd has the right to revise this Product Specification for continuous improvement, and will not previously notify customers the revised Specification with written notice.

12. OTHERS



Attached list:

Any matter not included in this specification shall be conferred between the both parties.

Performance Curve (Representative)

Charge Specialty	Discharge Specialty
<p>Charge: CC/CV 1C₁A, 4.2 V, 0.1×1C₁A cut off at RT Discharge: 1C₁A 2.75V cut off at RT</p>	<p>Charge: CC/CV 1C₁A, 4.2 V, 1C₁A, 5 C₁A , 10 C₁A, 15C₁A, 20 C₁A cut off at RT Discharge: 2.75V cut off at RT</p>
Temperature Specialty	Cycle Life
<p>Charge: CC/CV 1C₁A, 4.2V, 0.1×1C₁A cut off at RT Discharge: 1 C₁A, 2.5V cut off at RT</p>	<p>Charge: CC/CV 1C₁A, 4.2V, 0.1×1C₁A cut off at RT Discharge: 1C₁A, 2.75V cut off at RT</p>

Contact person: Carl

Sales manager

Technology supervisor

Email: xinchibatterysales@gmail.com

Phone/Whatsapp: +86 130 1196 2820

www.sinclithiumbattery.com

Liaoning Xinchi Lithium Technology Co.,Ltd

Address: No.10, North 2nd Road, Dalinghe Industrial Park, Linghai City, Jinzhou, Liaoning, China

QINHUANGDAO XINCHI PHOTOELECTRICITY TECHNOLOGY CO., LTD.

Address: At The 275-KM Spot To No.102 National Road South, Funing County, Qinhuangdao City, Hebei, China